

*D — Premier*  
White Paper

May, 2011

## 21<sup>st</sup> century High-End Audio Technologies

### Patented DAC design and Analog Digital Hybrid amplification technology

#### (ADH hybrid core®): *"The best of both worlds"*

- musicality of the Class A (voltage control) and efficiency of the class D (current output) working in parallel
- "power steering"-like design with the Class A amp in the driver's seat
- patented ultra-linear unity gain class A amplifier
- revolutionary 24/192 DAC located in the core of the Class A amp: patented zero processing I/V conversion
- best performances in real use conditions on every measurable criteria: THD, IMD, Output impedance, SNR...

### Exclusive HD asynchronous Wi-Fi streamer: *"The best cable is no cable"*

- HD asynchronous Wi-Fi data transmission protocol
- Internal DAC master-clock ensuring zero jitter reproduction
- smart buffering: instantaneous start and robust stream
- iTunes-based control interface with multi-device access
- seamless HD streaming from iTunes

### 21<sup>st</sup> century high precision phono stage: *"Serving the LP musical heritage"*

- low noise and hum-free differential design
- universal configurable MM/MC cartridge compatibility
- high precision digital RIAA processing
- LP ripping HD digital output

### Ultimate daisy chaining capability: *"Stacking layers of pleasure"*

- even more power and performances: 2x 400 W and 0.00025% THD in dual mono
- easy master - slave connection, stacking and control
- digital synchronized link
- multiple chaining options: dual-mono, bi-amp, multi-room

### Free online advanced customization tool: *"Your amp, your mood, your settings"*

- intuitive web-based interface
- advanced information and support
- extensive settings options: performance enhancement, comfort of use and protection

### First fully upgradable platform: *"It's getting better all the time"*

- software-driven analog hardware platform with 8 processors
- "down the road" feature activation and performance improvements:
- 2011: software upgrade 5.3 offering better sound quality (more powerful and responsive power supply) and new features (ex: daisy chaining)
- next: streaming, HDMI, active cross-over filtering, DSP-based optimization (ex. speaker/electronics matching)
- easy SD card software loading process

### Ultimate audiophile hub: *"A team can be more than sum of its parts"*

- best-in-class design for every function: inputs, power supply, ADC, DAC, Class A, Class D, remote
- 5 patented major innovations
- optimal interlinked architecture
- straight-wire integration philosophy: zero processing, shortest path

### Green technology: *"Smart Power"*

- reduced power loss and heat dissipation: 85% efficiency for 2x 240 W
- efficient planar transformer power supply (600 W and 2100 W peak): Power Factor Correction (PFC) and reduced hardly recyclable storage components
- green design and materials: small aluminum chassis, RoHS standard PCBs, no wires and insulators

## TECHNOLOGY INSIGHT

### *Why does it sound so good?*

Devialet D-Premier is the first amplifier based on ADH Technology, along with numerous other highly innovative Devialet-exclusive principles. They are all aiming at offering the best sound - whatever the speakers associated to the unit - as well as the most user-friendly and enjoyable experience. In short: «Technology made simple». This white paper presents the main technologies invented by Devialet for D-Premier.

### **ADH hybrid core: patented Analog Digital Hybrid amplification technology**

The original idea and first patent, which dates back to 2004, is to combine the two opposed technologies of amplification - analog and digital, aiming to obtain the best of both worlds: the linearity of the most acclaimed analog amplifiers (class A) with the power, efficiency and compactness of «digital» amplifiers (class D).

Although simple to explain, this alliance rapidly proved to be extremely difficult to implement, since it basically means connecting the two amplifiers in parallel. Finally, 4 years of extensive research were needed to achieve a working prototype.

The principle of Analog Digital Hybrid is simple:

- A genuine class A amplifier directly connected to the speaker drives the output voltage: as the master, it sets the sound of the whole ADH core, that's how what we hear is an analog amplifier.
- A digital amplifier is added in parallel to provide most of the current to the speaker. It is «slaved» to the analog amplifier so that it minimizes the current of the class A.

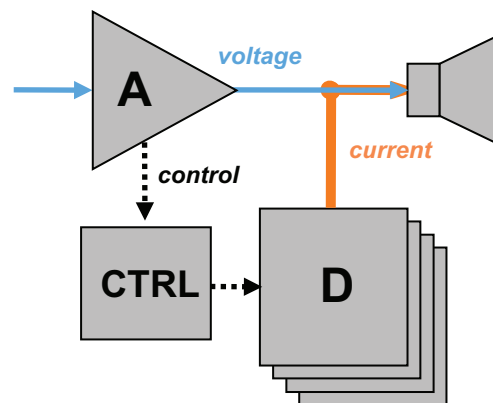

An illustration of this principle is the power steering of a car: the driver is assisted by a powerful engine to turn the wheels as they should be, easily hence precisely.

Two additional benefits derive from this successful association:

- The class A amplifier, which «sees» a much easier (read: ohmic) speaker to drive, corresponding to the current ratio of about 1:100 between both amplifiers, is made even more linear: as unexpected as it sounds, it is improved by the digital amplifier... Imagine that when you connect an 8 ohm-speaker, the class A in ADH only sees a light headphone equivalent load of 800 ohms to drive.
- The output impedance of the ADH core is equal to the class A impedance divided by this same assistance ratio: that's how a less than 1 milli-ohm figure is achieved over the whole bandwidth (not only the lows), which is so important to maintain all the other quality parameters against real, non-perfect speakers.

ADH Technology, combined with Devialet's exclusive DAC in a very favorable architecture, is responsible for D-Premier's sound transparency, immediately recognizable.

### **Innovating, optimal system architecture**

As good as it may be, the amplifier itself is not enough to offer a comprehensive audio solution: a lossless connection between the source and the amplifier is needed. The vanguard architecture of Devialet D-Premier breaks the traditional boundary between blocks, and removes interconnects between appliances, since the DAC and the class A amplifier overlap to make the shortest possible signal path of any audio system ever built: less than 5 cm / 2 in. between the resistances where the music voltage is born and the speaker binding posts. This is at least 10 times shorter, without all the possible degradation of an external interconnect: hum, noise, bandwidth and impedance matching. Moreover, the DAC directly outputs the same high voltage that is expected at the speaker output, so the ADH amplifier works at unity gain. Overall only 2 resistors and 2 capacitors in the whole system handle the music. No gain stage based on feedback with questionable impact on distortion, no nothing.

## Patented ultra linear, unity-gain class A amplifier

A specific class A amplifier is required to do the job in the ADH core: although it is most of the time highly assisted by the class D in providing current to set the ideal voltage to the speaker, it must also be able to output a high current over a short period of time, and absorb the ripple current of the digital amplifier. So it needs both a high current output capability and a low output impedance at high frequency.

This is achieved by a very innovative non-linear polarization scheme which allows a virtually infinite current while staying in class A, combined with a low power consumption. The intrinsic linearity and output impedance of this class A compare with the best units on the market, but remember they are further abundantly improved by the ADH combination.

A comprehensive demonstration highlighting the analog amplifier of the ADH core is to remove the digital amplifier daughter board: D-Premier still delivers very transparent sound, and only enters thermal protection when pushing the volume for too long.

## Patented ultra linear, high-voltage DAC

Moving further upstream, the DAC is the next key block of the chain that sets the music quality. It has been designed in light of the following observation: processing means altering. At system level, the gain stage is removed and the path of music is minimized for this reason.

In the DAC, the output current of the highest performance device available (T.I. PCM1792) is directly converted into high voltage without any processing in between: no operational amplifier, no current mirror. Instead, a fully original very complex leak-less path is designed to carry the original current of the DAC to the only two ultra high-linearity resistors in the system. The magic comes from the fact that the guiding elements around this path do not process the music.

Besides, the characteristics of any device is related to its temperature, so if temperature changes, music rendering changes as well. To make the system thermal distortion-proof, all the parts which build the guiding boundary are designed to operate at constant power (dual cascode), hence constant temperature.

## Patented single-stage, low noise, PFC power supply

The energy-efficient ADH core is fed by a very special switched-mode power supply: unlike so-called «linear» power supplies and traditional switched supplies, it draws power from the mains the way a light bulb does, following a very clean sinusoidal waveform. This not only complies with regulations applicable to higher power electrical devices required to perform PFC - Power Factor Correction, but overall ensures a very low noise sent to the mains and to the internal blocks.

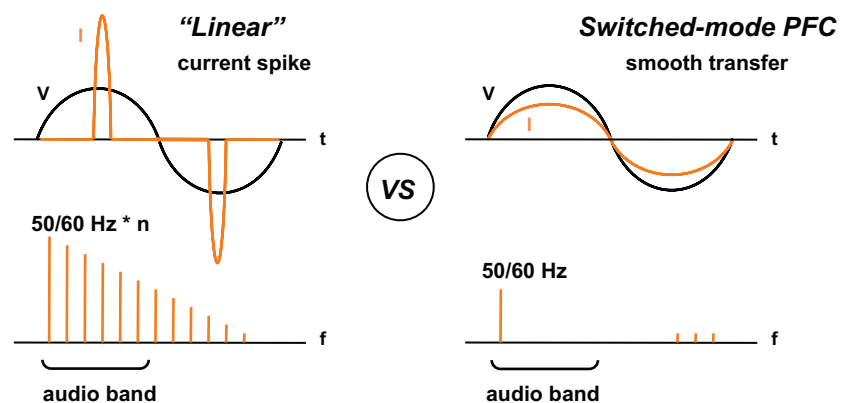

On the contrary, drawing an average 10 Amps from the mains using crest-rectification of a linear supply transmitting power only 10% of the time generates current spikes of 100 Amps, 100 or 120 times per second: all the harmonics of this disturbing noise source lay exactly in the audio band...

In D-Premier, the PFC feature is obtained with a single stage energy processing, hence less power loss and the traditional wire-wounded transformer is replaced by an in-house designed planar transformer made of very technological Printed Circuit Boards ensuring repetitive and much lower parasitic values. The processor-controlled supply of D-Premier also features extremely fast response to load transient and requires a much smaller amount of energy storage.

## Performances: parameters, figures & music

D-Premier has been thoroughly designed after identifying the appropriate parameters and associated figures setting a new standard defined as Live and Lossless® sound. Well known, traditionally discussed parameters prove to be insufficient to really qualify the transparency of an amplifier, which explains the extensive listening tests associated to measurements in the reviews. That's why we worked on defining our specific approach regarding these parameters.

Here is a key list against which D-Premier was evaluated throughout its design:

- Signal-to-Noise Ratio (SNR), reflects the noise floor level under which music becomes masked, ruining the original ambiance and emotion during pianissimo moments; experience shows that although human ear is able to dig tones well below the noise level, pushing this standard very far makes a noticeable difference, especially with high resolution recordings
- Total Harmonic Distortion (THD), reflects the amount of spurious harmonics added to a single tone, hence timbers fidelity, since instrument sound signature is made of the ratio between these harmonics
- InterModulation Distortion (IMD), reflects the amount of spurious combinations of several tones: beyond THD, a very low IMD is mandatory to render the sound of a large orchestra without adding blur and to provide the original spatial definition without mixing the multiple paths of sound together
- Frequency response, in both amplitude (BW) and phase, defines the sound scene breadth and breath integrity, as well as the accuracy of high pitch timbers (for example, muted trumpet which tends to become aggressive with a non-linear phase response)
- Output impedance ( $Z_{out}$ ), defines the stiffness with which the amplifier sets the output voltage against the speaker's non-linearities and resonances (intrinsic and room's); without an extremely low figure of this parameter, all the above discussed qualities measurable on ideal lab loads are lost in real life condition; the math is simple: take a low distortion value for a speaker of only 1% (-40 dB): to maintain a -100 dB THD figure (0.001%) thru this speaker, an impedance ratio between the amplifier and the speaker of 1:1000 is required that is, for a 4-ohm speaker, a maximum output impedance of 0.004 ohm
- Thermal distortion: since the characteristics of any electronic device depends on its temperature, a variable working power leads to a non-constant operating temperature, hence non-constant sound reproduction; various time constants of thermal inertia are found, leading to different kinds of impact on sound: short term thermal distortion alters the groove and the phrasing integrity - a system without this artifact is perceived as «fast», and non-tonal sounds like percussions become incredibly realistic; a longer term effect reduces the immediacy of forte / piano subito, and the emotion deriving from this contrast

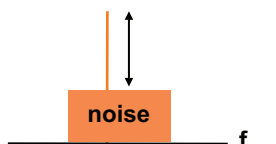

■ **SNR**  
*Signal / Noise Ratio*

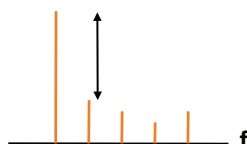

■ **THD**  
*Harmonic Distortion*

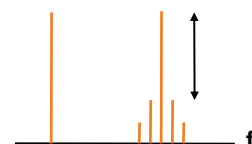

■ **IMD**  
*InterModulation Distortion*

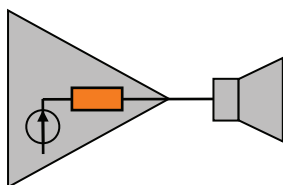

■ **Zout**  
*Output impedance*

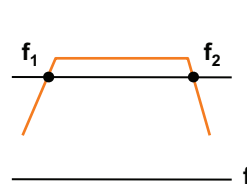

■ **BW & phase**  
*Bandwidth, phase rotation*

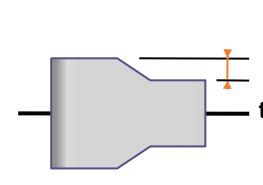

■ **Thermal distortion**

D-Premier has been designed with strictly no compromise on any of those parameters, pushing the studies via permanent mutual challenge within the team. This is how the following figures were achieved:

PARAMETERS	«HIGH END»	D-PREMIER	RATIO	CONDITION
SNR	100 dB	130 dB	1:30	unweighted
THD	80 dB	100 dB	1:10	full P
IMD	70 dB	100 dB	1:30	SMTPE
Zout	100 mΩ	1 mΩ	1:100	full BW
BW	30Hz~10kHz	DC~30kHz	1:3	-0.1 dB
	5Hz~60kHz	DC~95kHz		-3 dB
Phase	20°	0.4°	1:50	20 kHz
	35°	1.8°	1:20	40 kHz
Thermal Distortion		<i>non measurable</i>		

## Versatile DSP

D-Premier has been designed as an open platform which integrates numerous configurations and meets everyone's need, by adding a DSP at the crossroad between inputs and outputs (ADH, S/PDIF output, analog pre/sub-out): in standalone stereo mode, the DSP acts as a straight wire and only performs volume control and RIAA phono correction; yet, this full-featured floating-point engine (SHARC) is available for extended uses.

Careful studies proved that the optimal (read: most linear) volume control is today achieved in the digital domain, that's why the analog inputs are also internally routed and handled as balanced inputs, the outer RCA ring being insulated (doubled chain, removing the traditional ground noise and distortion), then sampled at 24 bits, 96 or 192 kSPS by a professional, ultimate performance ADC (T.I. PCM4220).

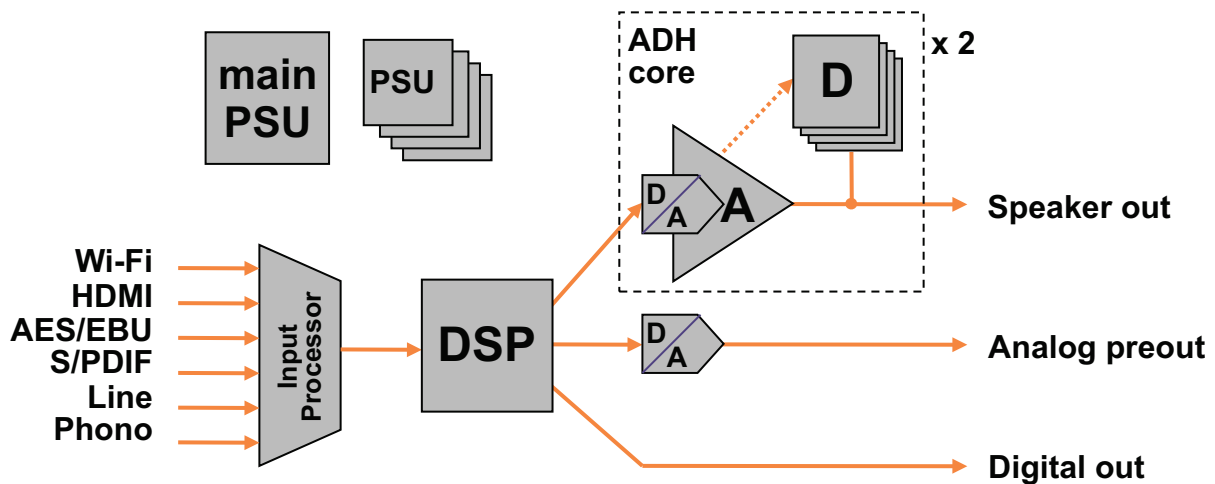

## 21<sup>st</sup> Century high precision phono stage: "Serving the LP musical heritage"

D-Premier is not only designed as an ideal digital-in amplifier. It includes an unprecedented high end configurable phono stage (compatible with all cartridges: MM, MC, stereo and mono without Pre-Pre required.), also taking advantage of the synergies of a close integration with our unique amplification technology.

- Low noise and hum-free differential design:

Considering the electrical radiations (mostly captured in the ground) affect equally the ground & signal wires coming out of the cartridge, the differential topology removes unwanted noise and parasitics. Tonearm grounding is no more an issue, and our dedicated phono ground connection is not necessarily needed.

- Universal configurable MM/MC cartridge compatibility

D-Premier phono input features a configurable resistor and a capacitor array. More than 100 presets are available to fine tune the audio result with any MC/MM cartridge. The configurator interface on our website allows you to easily adjust those settings.

- High precision digital RIAA processing

Digitalizing is especially well suited for phono signals: since the RIAA processing applied during mastering enhances high frequencies, a greater resolution is obtained in the frequency range where it is most needed. We get more bits available to describe very small and fast wave forms. The RIAA correction is done in the digital domain using our real-time high resolution DSP capabilities. The precision of the applied correction regarding the theoretical curve is more accurate than +/- 0.01 dB, whereas 0.5 dB is a high performance for an analog design. Moreover, the same RIAA accentuation does not match all recordings. With D-Premier you can instantly select the appropriate reverse RIAA curve between 1953 standard and post 1976 revision (using the central button of the remote control). Older correction curves are also available on request because we do not forget records released before 1953!

- Single stage gain without additional noise nor distortion nor range limitation

D-Premier performs RIAA correction and signal amplification in distinct stages. We fully benefit from the synergies of the integrated architecture of D-Premier. Since it is a unity gain amplifier - where the digital signal is directly converted with the output voltage applied to the speakers - adding gain is just doing the math! It can't be wrong, non-linear nor limited, and it cannot be unbalanced neither between left and right channels. Unless you decide to do so in order to compensate a non-perfect position of the cartridge between vertical/horizontal axes i.e. L/R channels. All the quality of our amplification design also contributes to the audio result: ultra low noise floor, low distortion and intermodulation, dynamic response and power.

- LP ripping HD digital output

Thanks to its output with configurable sampling rate up to 192 kHz/24 bit, D-Premier is also an ultimate LP ripper, bridging past recording technology and our digital era.

## **Exclusive HD asynchronous Wi-Fi streamer: "The best cable is no cable"**

Since the very first D-Premier, all units are ready to receive an additional streamer module through an easy operation and software upgrade. Looking to offer the best sound quality with the smoothest user experience, we always considered streaming as the best possible input for D-Premier.

Our technology and choices are based on:

- a HD asynchronous Wi-Fi data transmission protocol with smart buffering

This is the only way to do things the right way: transferring the music as data packets via a data transmission protocol, recomposing the music files, and "play" them internally. So we developed our own solution based on Wi-Fi 802.11n standard. It ensures data packets transmission integrity and continuity, using multiple backup methods and a smart buffering approach. This buffering is constantly optimized in order to have an instantaneous start and robust stream at the same time.

- an Internal DAC master-clock ensuring zero-jitter reproduction

Having a single clock running the signal throughout the system is a key concept of jitter-free digital transmission. Therefore, the internal DAC clock of D-Premier controls all the data transmission and replay process from the computer where the files are stored to the DAC.

- an iTunes-based control interface with multi-device access

We choose iTunes as an interface for the streaming. It is the most universal, user-friendly solution, and most of all, it natively offers multi-device access. An iPod, iPad or iPhone can be used as a remote to control iTunes on a computer. So iTunes is only where you select your tracks - and just that - since the music files are actually «played» inside the D-Premier. A driver installed on the computer sees what iTunes is doing and interacts accordingly with the D-Premier. FLAC files users can easily convert their files to other lossless formats and transfer all their library to iTunes. Even high resolution files up to 192kHz / 24bit can be used, since the limitations of iTunes for handling HD files is not no longer an issue with our process: no other software is needed.

Future software upgrades will extend the possibilities of the streamer, supporting Airplay protocol or being recognized as an external sound card by the computer.

## Ultimate daisy chaining capabilities

Several D-Premier units can be daisy chained:

- in order to get even more power and performances: 2x400 W and 0,00025% THD in dual mono
- through an easy master - slave connection, stacking and control operation
- with a digital synchronized link
- and multiple chaining options: dual-mono, bi-amp, multi-room

## Free online advanced customization tool

D-Premier is also configurable to the exact user's need. A web-based user friendly interface helps customize virtually everything in D-Premier: type, name and parameters (like phono loading) of the sources, subwoofer management and analog / digital pre-out, speaker impedance and maximum power, etc...

Both the configuration data from the online tool and the software upgrade package for the 8 embedded processors are easily loaded into D-Premier via SD-Card - the slot is located at the rear of the unit.

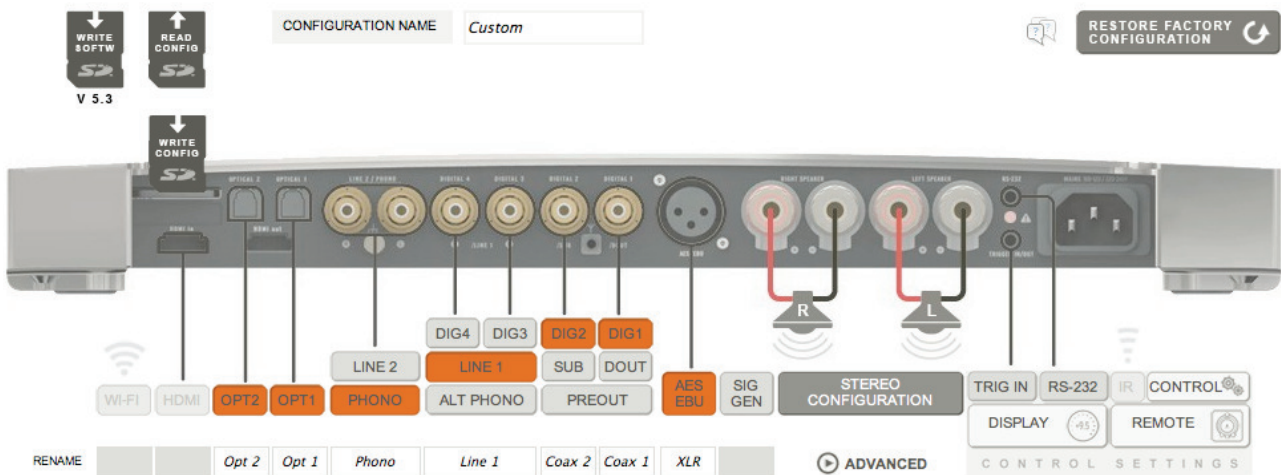

## First fully upgradable platform

Prepare to be surprised, since new major features will be released. Being a software-driven analog hardware platform, we can add new features as well as new improvements «down the road».

For instance, the 5.3 software version released in May 2011 offers a real sound quality enforcement due to a better management of the power supply, making it even more powerful and responsive. Peak power supply available has jumped for instance from 800 W to 2100 W! This version also allows RS-232 control, adds comfort features like the possibility of checking the incoming digital sampling rate through a long press on the source button.

There is more to come:

- active cross-over management for multi-amplification (the filters are already running in the DSP but are configured as... bit-perfect straight wires)
- activation of the HDMI inputs
- other DSP-based optimizations like the electronics/speaker matching.

## Design philosophy «A team can be more than the sum of its parts»

D-Premier, the amplifier that looks and sounds like no other, is the outcome of a different team running an original approach of the design process. Gathering talents from numerous electronics areas, like aerospace and telecom - not only audio, Devialet R&D literally started from the blank slate by defining what makes a good amplifier (parameters & figures), then finding how to build and lay out the functional blocks to meet these requirements, imagining new, optimal boundaries in between.

Many radical choices in D-Premier definition were made with the user experience in mind, like transposing the precise feeling of a large volume wheel usually found on thick front panels, to a radio link remote, and striving to provide a seamless operation thru this link where technology vanishes behind a maximum comfort. Once again, the best of both worlds is achieved: a precise «analog» control, henceforth exactly accessible from the listening spot. «We really designed the product we wanted at home», and compromise was never an option.

Innovation has been the primary fuel to the process, as reflected by the 5 patents spawned. A fertile blend of theoretical analysis, simulation and prototyping was needed to achieve the targeted standards.

For example, to obtain such a low noise system, efforts must be focussed on the noisiest link in the chain (masking / weakest link effect). Unfortunately, it is not possible to physically measure the contribution of each link, hence a mixed, iterative process between theory and measurement is needed... along with a boundless amount of determination. The final product is also the result of stringent studies to understand unclear physical phenomena (like passive components technologies) and imagine pragmatic, industrial responses.

Another example: most electronic devices feature various physical phenomena all leading to adding noise related to their vibrating environment; this is also called microphonic sensitivity, and explains why the sound of most devices can be improved by adding vibration insulators under their mounting feet.

As for the thermal noise in D-Premier, the same utmost care has been taken to properly cancel this sensitivity throughout the whole design, and achieve figures for a full system DAC+preamp+amp of the most high-end single elements.

Remember Miles Davis' «Less is more» creed: if the «short wire» principle should drive the implementation of each function, it's usually quite impossible to «do» nothing, neither in analog nor in digital domains. The DAC is a vibrant illustration: the music path is reduced to a ridiculously low number of devices, whereas the surrounding guides inversely grow complex to keep this music path pure and perfect. And this straight wire discipline directly transcribes into the obvious feeling of genuineness of the sound.

Systematic worst case studies (like Monte Carlo) on all parameters were run to ensure by design all D-Premier coming out of the production line fully comply with their specifications and also feature the expected extreme reliability. And they do, whatever the characteristics of the 2.500 electronic parts within their authorized range: no sorting, no pairing, no tuning, at the expense of more complex, tolerant schematics embedding built-in auto-compensation mechanisms. Nothing is left unpredicted nor unexplained.

[mathias.moronvalle@devialet.com](mailto:mathias.moronvalle@devialet.com)

+33 1 44 88 27 25

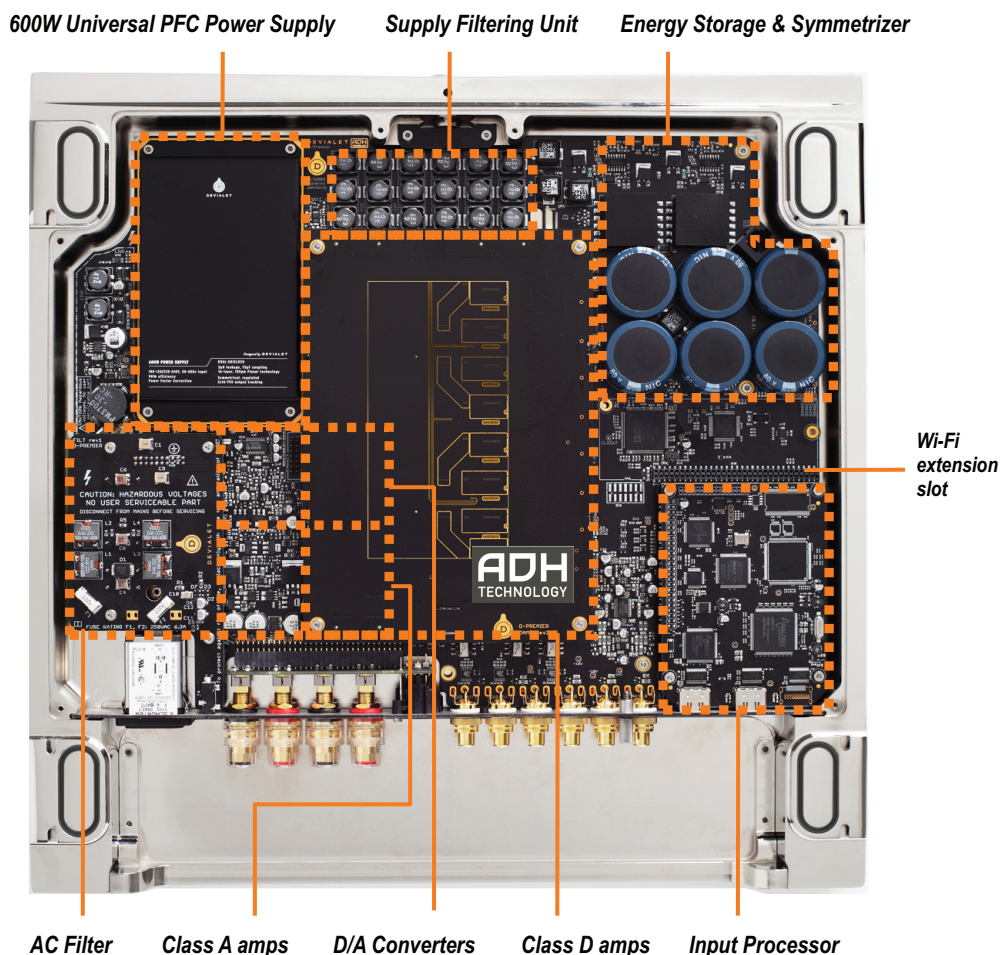

### Key points

- This is not a class D! but a genuine analog amplifier + integrated DAC
- Original design process from the blank slate & extensive innovation (5 patents) for such a different outcome
- ADH Analog Digital Hybrid amplification technology:
  - a class A and a class D amplifiers connected in parallel to the speaker output
  - class A is the master of the output: it sets the sound transparency
  - class D is slaved to the class A to provide most of the current
  - class A is improved by the assistance of class D (yet unexpected): ADH is more accurate than class A
- Very special innovative class A: ultra linear, low output impedance, low power consumption yet infinite available output current in class A
- Very innovative & ultimate DAC with direct high voltage output (no gain stage), located in the core of the class A: shortest possible signal path ever
- Smart, PFC switched-mode power supply using a planar transformer, much less noisy than traditional switched and so-called linear supplies
- High quality analog inputs, including an advanced versatile phono input, matching the quality standard of the amplifier
- Open platform ready for many new exciting features, most of them via software upgrade
- Wi-Fi streaming-ready with an extension board